



10. Maintenance and Cleaning

The following points have to be considered during the inspection:

1. All screws for installing the devices or parts of the device have to be tightly connected and must not be corroded. 2. There must not be any deformations on the housing, color lenses, fixations and installation spots (ceiling, suspension, trussing). 3. Mechanically moved parts must not show any traces of wearing and must not rotate with unbalances. 4. The electric power supply cables must not show any damage, material fatigue or sediments.

Further instructions depending on the installation spot and usage have to be adhered by a skilled installer and any safety problems have to be removed.



CAUTION!

Disconnect from mains before starting maintenance operation.

In order to make the lights in good condition and extend the life time, we suggest a regular cleaning to the lights. 1) Clean the inside and outside lens each week to avoid the weakness of the lights due to accumulation of dust. 2) Clean the fan each week. 3) A detailed electric check by approved electrical engineer each three month, make sure that the circuit contacts are in good condition, prevent the poor contact of circuit from overheating.

We recommend a frequent cleaning of the device. Please use a moist, lint-free cloth. Never use alcohol or solvents. There are no serviceable parts inside the device. Please refer to the instructions under "Installation instructions". Should you need any spare parts, please order genuine parts from your local dealer

LED ZOOM BEAM WASH

19pcs 15W RGBW 4-in-1

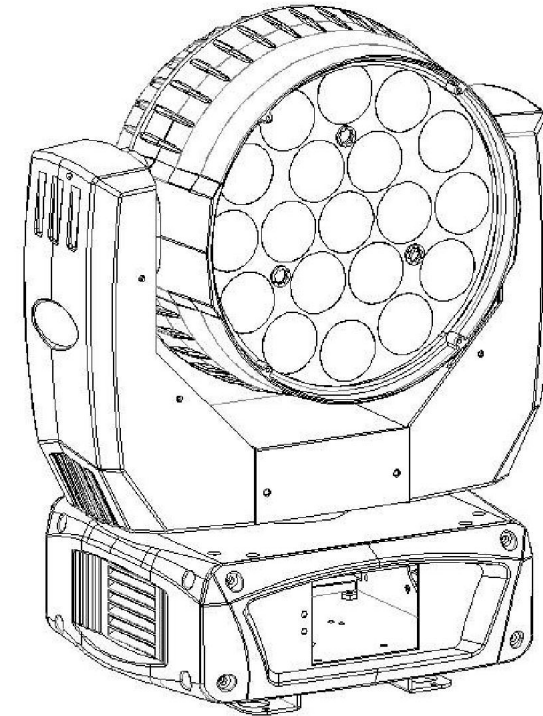

CE F IP20 LED 0.2m t_a 40°C t_c 150°C

User Manual

KEEP THIS MANUAL FOR FUTURE NEEDS

1. Unpacking

Thank you for choosing LED 19pcs ZOOM. For your own safety, please read this manual before installing the device. This manual covers the important information on installation and applications. Please install and operate the fixture with following instructions. Meanwhile, please keep this manual well for future needs.

LED BEAM 1915 ZOOM is made of a new type of high temperature strength of engineering plastics and cast aluminum casing with nice outlook. The fixture is designed and manufactured strictly following CE standards, complying with international standard DMX512 protocol. It's available independently controlled and linkable with each other for operation. And it is applicable for large-scale live performances, theater, studio, nightclubs and discos.

4-IN-1 LEDs(RGBW) which features high brightness and stability. Please carefully unpack it when you receive the fixture and check whether it is damaged during the transportation. And please check whether the following items are included inside the box:

Moving Head-----One	Signal Cable----One
Hanging Bracket-----Two	Power Cable----One
Safety Cable-----one	User Manual----One

9. Key Features

Source: 19pcs 15W high brightness RGBW 4-in-1 LEDs
 ZOOM: 3 ZOOM motors work together with the same step
 Working lifetime: 100,000 hours with low power consumption
 Channel: 16/24 channels with macro effects
 Control: DMX512/Master-slave/Auto/Sound
 Strobe: 1-25 times/second
 PAN: 540 degree with 16bit rotate
 Tilt: 270 degree with 16bit rotate
 Beam angle: 8-50 degrees
 Color: RGBW infinite mixture
 Dimmer: 0-100% linear dimming system
 Display: LCD blue display with Chinese and English language.
 Protection: Auto temperature control system with big cooling fan.
 Quiet, smooth and fast PAN/TILT movement
 Low noise and efficient FAN cooling system
 Built-in pre-programs with macro effects.
 IEC power connector
 45 ℃ max ambient temperature
 IP20 protection rating
 3-Pin XLR DMX input/output
 Function: With LED shutter, scan position memory and auto reposition.
 LED rainbow effect. LED in circle. Smooth and fast speed, super low noise.
 Perfectly suitable for stage, theatre, TV studio, rental, DISCO and more
 Packing details for 1pc/ctn
 Net Weight: 7.5 Kg
 Gross Weight: 9.2 Kg
 Carton Package Size: 38*26*47.5 cm

8. Photometric Data:

LUX Data of 8 degree beam angle:

R	7200LUX@2m	1900LUX@4m	1000LUX@6m	620LUX@8m
G	14800LUX@2m	3900LUX@4m	1900LUX@6m	1200LUX@8m
B	14800LUX@2m	3950LUX@4m	1950LUX@6m	1200LUX@8m
W	15200LUX@2m	3850LUX@4m	1950LUX@6m	1200 LUX@8m
RGBW	41100LUX@2m	10000LUX@4m	4600LUX@6m	2550LUX@8m

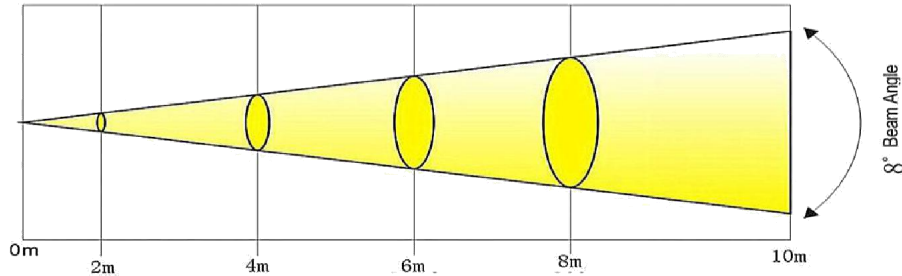

LUX Data of 50 degree beam angle:

R	1150 LUX@2m	310 LUX@4m	200 LUX@6m	110 LUX@8m
G	2450 LUX@2m	100 LUX@4m	350 LUX@6m	180 LUX@8m
B	2450 LUX@2m	710 LUX@4m	350 LUX@6m	200 LUX@8m
W	2350 LUX@2m	700 LUX@4m	320 LUX@6m	200 LUX@8m
RGBW	6600 LUX@2m	2000 LUX@4m	1200 LUX@6m	700 LUX@8m

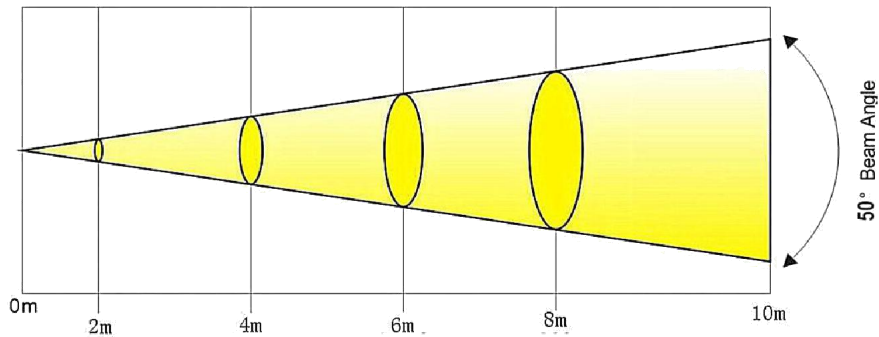

2. Safety Instructions



CAUTION!
Be careful with your operations. With a dangerous voltage you can suffer a dangerous electric shock when touching wires!

This device has left the factory in perfect condition. In order to maintain this condition and to ensure a safe operation, it is absolutely necessary for the user to follow the safety instructions and warning notes written in this user manual.

Important:
Damages caused by the disregard of this user manual are not subject to warranty. The dealer will not accept liability for any resulting defects or problems.

If the device has been exposed to temperature changes due to environmental changes, do not switch it on immediately. The arising condensation could damage the device. Leave the device switched off until it has reached room temperature.

This device falls under protection-class I. Therefore it is essential that the device be earthed.

The electric connection must carry out by qualified person.

The device shall only be used with rate voltage and frequency.

Make sure that the available voltage is not higher than stated at the end of this manual.

Make sure the power cord is never crimped or damaged by sharp edges. If this would be the case, replacement of the cable must be done by an authorized dealer.

Always disconnect from the mains, when the device is not in use or before cleaning it. Only handle the power cord by the plug. Never pull out the plug by tugging the power cord.

During initial start-up some smoke or smell may arise. This is a normal process and does not necessarily mean that the device is defective, it should decrease gradually.

Please don't project the beam onto combustible substances.

Fixtures cannot be installed on combustible substances, keep more than 50cm distance with wall for smooth air flow, so there should be no shelter for fans and ventilation for heat radiation.

If the external flexible cable or cord of this luminaire is damaged, it shall be exclusively replaced by the manufacturer or his service agent or a similar qualified person in order to avoid a hazard.

3. Operation Instructions

- The moving head is for wash effect for on-site decoration purpose.
- Don't turn on the fixture if it's been through severe temperature difference like after transportation because it might damage the light due to the environment changes. So make sure to operate the fixture until it is in normal temperature.
- This light should be keep away from strong shaking during any transportation or movement. - Don't pull up the light by only the head, or it might cause damages to the mechanical parts. - Don't expose the fixture in overheat, moisture or environment with too much dust when installing it. And don't lay any power cables on the floor. Or it might cause electronic shock to the people.
- Make sure the installation place is in good safety condition before installing the fixture.
- Make sure to put the safety chain and check whether the screws are screwed properly when installing the fixture.
- Make sure the lens are in good condition. It's recommended to replace the units if there are any damages or severe scratch.
- Make sure the fixture is operated by qualified personnel who knows the fixture before using.
- Keep the original packages if any second shipment is needed.
- Don't try to change the fixtures without any instruction by the manufacturer or the appointed repairing agencies.
- It is not in warranty range if there are any malfunctions from not following the user manual to operate or any illegal operation, like shock short circuit, electronic shock, lamp broke, etc.

4. Mounting and Installation

Cautions: For added protection mount the fixtures in areas outside walking paths, seating areas, or in areas were the fixture might be reached by unauthorized personnel.

Before mounting the fixture to any surface, make sure that the installation area can hold a minimum point load of 10 times the device's weight.

Fixture installation must always be secured with a secondary safety attachment, such as an appropriate safety cable.

16 Channels mode:

CH	Function	DMX Value	Description
1	Pan	0-255	0-540 degree
2	Pan Fine	0-255	16 bit
3	Tilt	0-255	0-270 degree
4	Tilt Fine	0-255	16 bit
5	Pan/Tilt Speed	0-255	Speed from fast to slow
6	Macro Dimming	0-255	Linear dimming from dark to bright
7	Strobe	0-3	No function
		4-95	Strobe with the same step from slow to fast (1HZ-25HZ)
		96-176	Random Strobe
		177-255	Thunder Strobe
8	R dimming	0-255	Red dimming from dark to bright
9	G dimming	0-255	Green dimming from dark to bright
10	B dimming	0-255	Blue dimming from dark to bright
11	W dimming	0-255	White dimming from dark to bright
12	ZOOM	0-255	
13	Effect show	0-255	(Built-in effect show) about 10 kinds of effcet
14	Effect speed	0-255	From fast to slow
15	Macro function(Please operate against CH13 and Ch14)	0-49	CH 1 to CH 12 workable
		50-99	Effect show (Built-in effect)
		100-149	Auto run 1
		150-199	Auto run 2
		200-255	Sound activated
16	Reset	0-99	No function
		100-250	No function
		251-255	Reset, workable after 3 seconds

7. DMX Channels

24 Channels mode:

CH	Function	DMX Value	Description
1	Pan	0-255	0-540 degree
2	Pan Fine	0-255	16 bit
3	Tilt	0-255	0-270 degree
4	Tilt Fine	0-255	16 bit
5	Pan/Tilt Speed	0-255	Speed from fast to slow
6	ZOOM	0-255	
7	Macro dimming	0-255	Linear dimming from dark to bright
8	Strobe	0-3	No function
		4-95	Strobe with the same step from slow to fast (1HZ-25HZ)
		96-176	Random Strobe
		177-255	Thunder Strobe
9	R1 dimming	0-255	Area 1 Red dimming from dark to bright
10	G1 dimming	0-255	Area 1 Green dimming from dark to bright
11	B1 dimming	0-255	Area 1 Blue dimming from dark to bright
12	W1 dimming	0-255	Area 1 White dimming from dark to bright
13	R2 dimming	0-255	Area 2 Red dimming from dark to bright
14	G2 dimming	0-255	Area 2 Green dimming from dark to bright
15	B2 dimming	0-255	Area 2 Blue dimming from dark to bright
16	W2 dimming	0-255	Area 2 White dimming from dark to bright
17	R3 dimming	0-255	Area 3 Red dimming from dark to bright
18	G3 dimming	0-255	Area 3 Green dimming from dark to bright
19	B3 dimming	0-255	Area 3 Blue dimming from dark to bright
20	W3 dimming	0-255	Area 3 White dimming from dark to bright
21	Effect show	0-255	(Built-in effect show)9 kinds of effect
22	Effect speed	0-255	From fast to slow
23	Macro function	0-49	CH 1 to CH 12 workable
		50-99	Effect show (Built-in effect)
		100-149	Auto run 1
		150-199	Auto run 2
		200-255	Sound activated
24	Reset	0-99	No function
		100-250	No function
		251-255	Reset and workable after 3 seconds

Never stand directly below the device when mounting, removing, or servicing the fixture from a periodic safety inspection of all installation material and the fixture. If you lack these qualifications, do not attempt the installation yourself. Improper installation can result in bodily injury.

Be sure to complete all rigging and installation procedures before connecting the main power cord to the appropriate wall outlet.

Clamp Mounting: The LEDBEAM 190w provides a unique mounting bracket assembly that integrates the bottom of the base, the included "Omega Bracket," and the safety cable rigging point in one unit (see the illustration below). When mounting this fixture to truss be sure to secure an appropriately rated clamp to the included omega bracket using a M10 screw fitted through the center hole of the

"omega bracket". As an added safety measure be sure to attached at least one properly rated safety cable to the fixture using on of the safety cable rigging point integrated in the base assembly

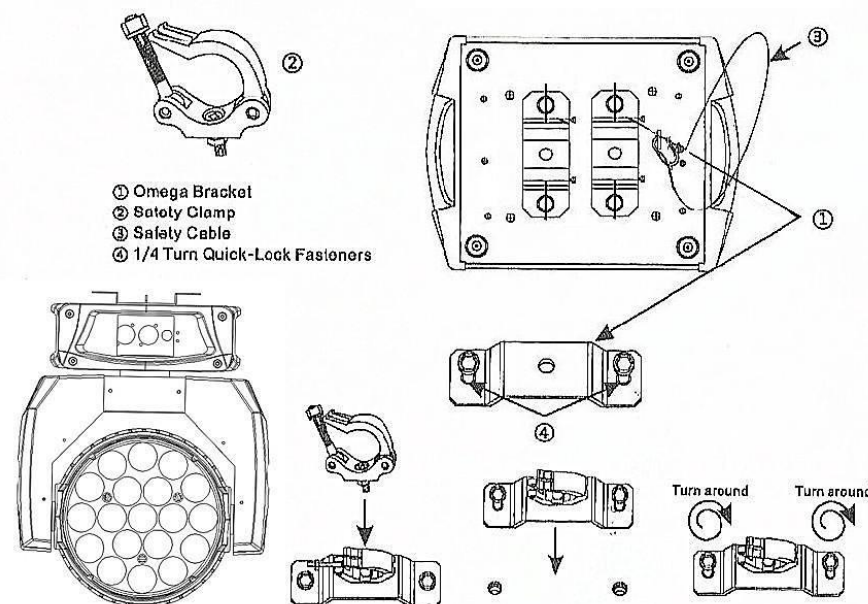

Regardless of the rigging option you choose for your 19pcs zoom, always be sure to secure your fixture with a safety cable. The fixture provides a built-in rigging point for a safety cable on the hanging bracket as illustrated above. Be sure to only use the designated rigging point for the safety cable and never secure a safety cable to a carrying handle.

5. DMX-512 control connections

Connect the provided XLR cable to the female 3-pin XLR output of your controller and the other side to the male 3-pin XLR input of the moving head. You can chain multiple Moving heads be connected together through serial linking. The cable needed should be two core, screened cable with XLR input and output connectors. Please refer to the diagram below. DMX-512 connection with DMX terminator

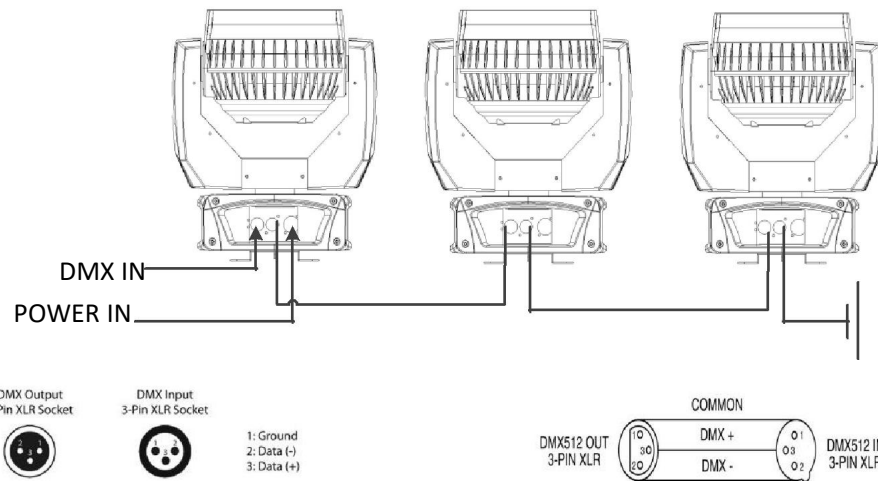

For installations where the DMX cable has to run a long distance or is in an electrically noisy environment, such as in a discotheque, it is recommended to use a DMX terminator. This helps in preventing corruption of the digital control signal by electrical noise. The DMX terminator is simply an XLR plug with a 120 Ω resistor connected between pins 2 and 3, which is then plugged into the output XLR socket of the last fixture in the chain. Please see illustrations below.

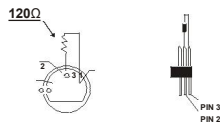

6. Menu Operations

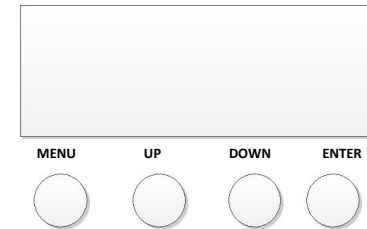

Operate instruction details

1. DMX Address Set

Press "Enter" to enter setting mode. Press "UP" or "DOWN" to adjust then press "Enter" to remain setting.

2. Work Mode Set

This is to set the work mode.

Press "Enter" to enter setting mode. Press "UP" or "DOWN" to adjust then press "Enter" to remain setting.

Work mode selectable:

- DMX512
- Slow
- Fast
- Sound
- Slave

"DMX512" is for DMX512 controller mode, "Slow" and "Fast" is in Auto run mode. "Sound" is for sound activated mode. "Slave" is for slave mode.

3. Invert PAN

Press "Enter" to enter setting mode. Press "UP" or "DOWN" to adjust.

"Yes" means invert rotate, "No" means no invert rotate.

Press "Enter" to remain your setting

4. Invert TILT

Press "Enter" to enter setting mode. Press "UP" or "DOWN" to adjust.

"Yes" means invert rotate, "No" means no invert rotate.

Press "Enter" to remain your setting

5. Display Set (Display backlight setting)

Press "Enter" to enter setting mode. Press "UP" or "DOWN" to adjust

"Yes" means the backlight keep open,

"No" means the backlight will close in 20 seconds without pressing and key and once pressing some key the backlight will reopen.

6. Channel Mode Set

Press "Enter" to enter setting mode. Press "UP" or "DOWN" to choose your mode.

24 CH Mode: 24 channels mode

16 CH Mode: 16 channels mode

7. Restore Factory Settings

Restore all the data to factory mode.

8. Reset

Press "Reset" and the fixture will rest after 3 seconds.